

LIGNUMM
AĞAÇ İŞLEME MAKİNELERİ

CE

TR

Lignum Ağaç İşleme Makineleri palet üretimi ve ağaç işleme endüstrisi için makineler üreten bir şirkettir. Şirket olarak her zaman alanımızda en iyi olma ilkesini benimseriz. Müşterilerimizin memnuniyeti ve talepleri bizim için çok önemli, bu nedenle sektörün getirdikerini sürekli takip etmekteyiz.

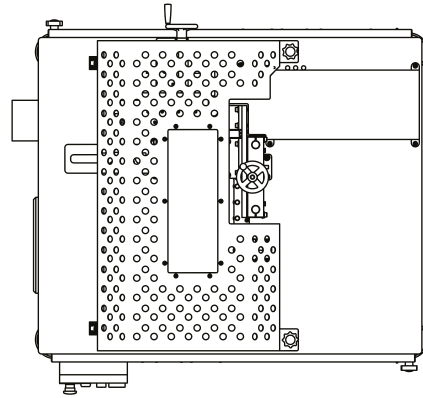
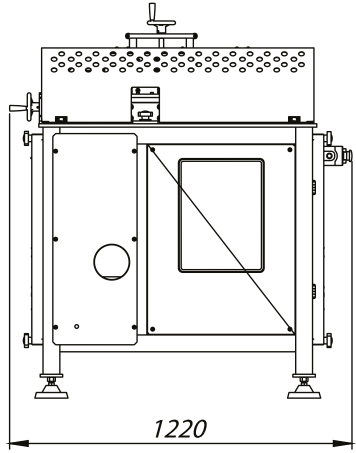
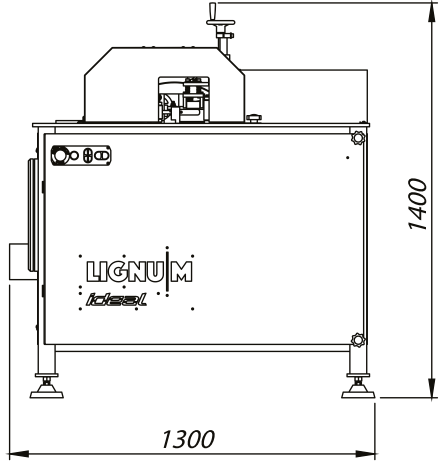

Testere Motor Gücü 5,5 kW

Toplam Güç 6,5 kW

Besleme Voltajı 380 - 400 V AC

Kontrol Ünitesi Voltajı 24 V DC

Hava Basıncı 6 Bar

Toplam Ağırlık 490 kg

Kesme Yüksekliği Min.60 mm - Max.100 mm

Kesme Uzunluğu Min.60 mm - Max.170 mm

Kesme Geniřliđi Min.75 mm - Max.150 mm

Kapasite 60 parça / dakika

Testere Hızı 4166 devir / dakika

Testere Çapı Ø 400 mm

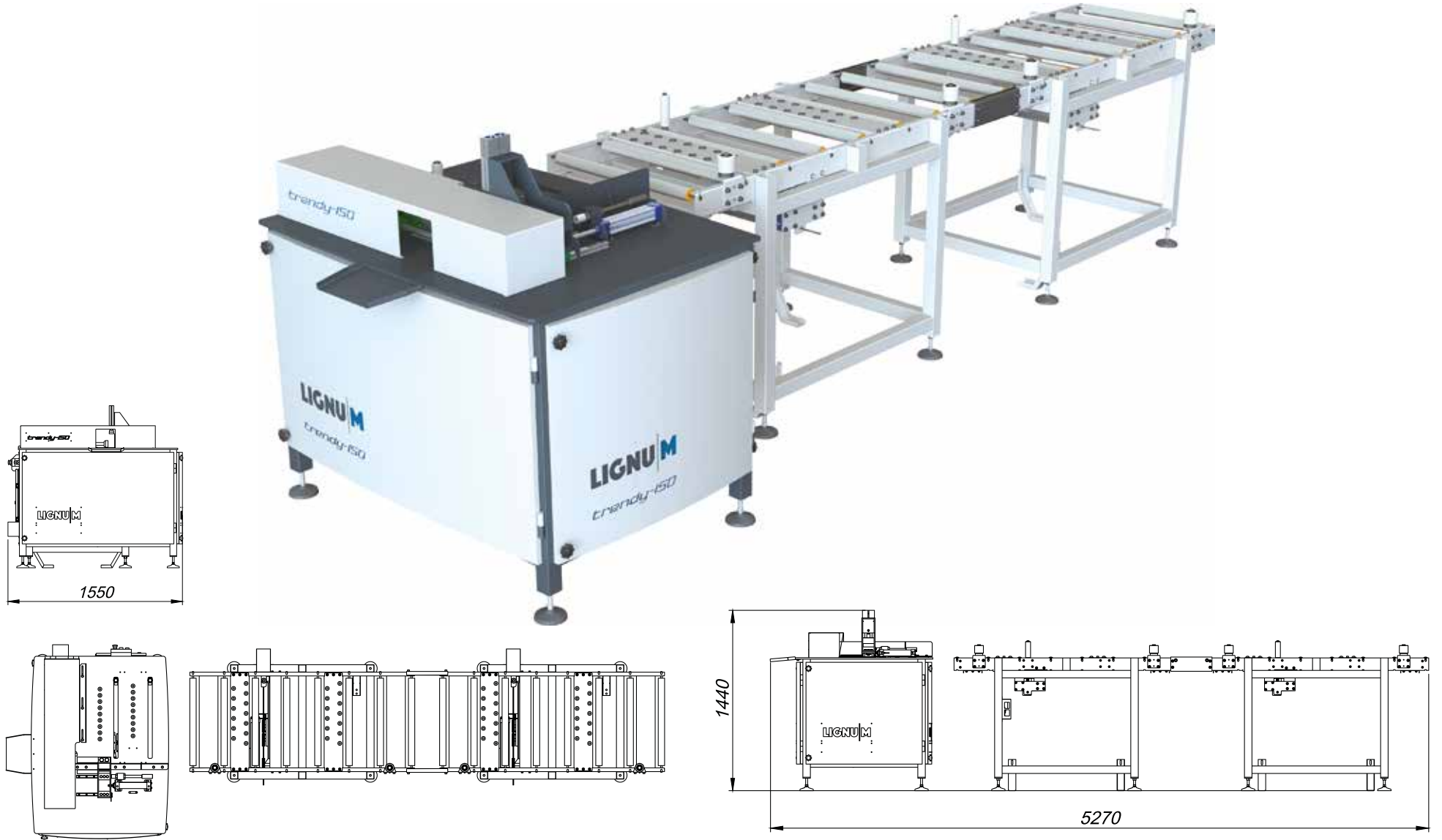

Testere Motor Gücü 5,5 kW
Testere Çapı Ø 500 mm
Kesme Yüksekliği Min. 60 mm - Max. 150 mm

Kesme Uzunluğu Min. 60 mm – Maks. 150 mm
Kesme Genişliği Min. 60 mm – Maks. 150 mm
Kesme Hızı 30 parça / dakika
Çalışma Sistemi Pnömatik

Çalışma Basıncı Min. 6 Bar
Kontrol Tipi PLC
Ağırlık 530 kg

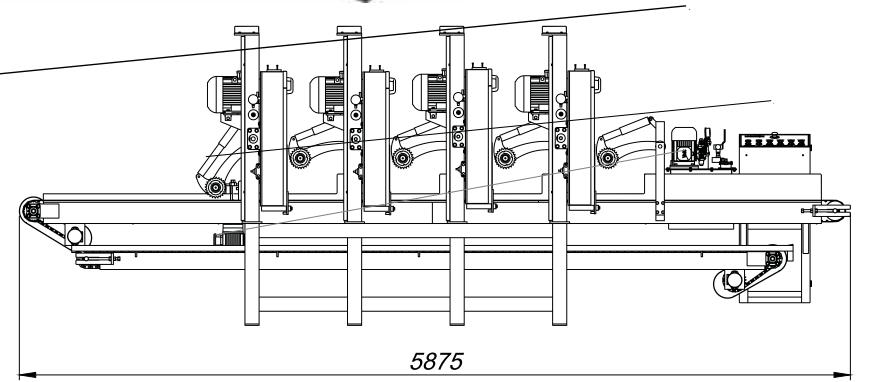
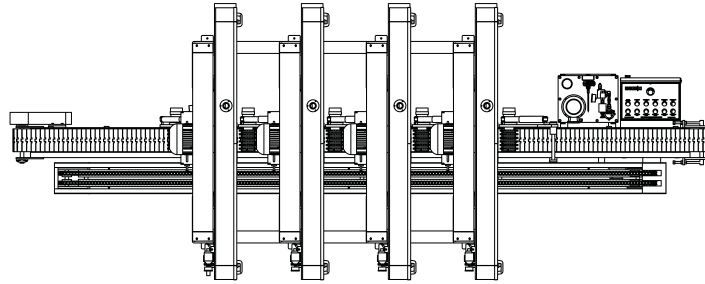
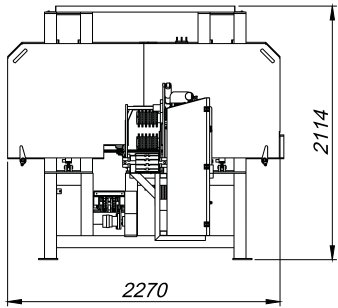

Kesme Yüksekliği	Min. 10 mm – Maks. 260 mm
Kesme Geniřlięi	Maks. 250 mm
Kasnak apı	Ø 830 mm
Malz. Geiř Yükseklięi	Min. 20 mm – Maks. 350 mm
Malz. Geiř Geniřlięi	Min. 50 mm – Maks. 250 mm

Testere Motor Gücü	11 kW
Konveyör Geniřlięi	190 mm (<i>Paslanmaz řerit</i>)
Konveyör Uzunluęu	5500 mm
Aęırlık	4200 kg

Kesme Hızı	Min. 5 m/dk – Maks. 40 m/dk
Hidrolik Motor	1,5 kW
Konveyör Dönüř Motoru	Hidrolik

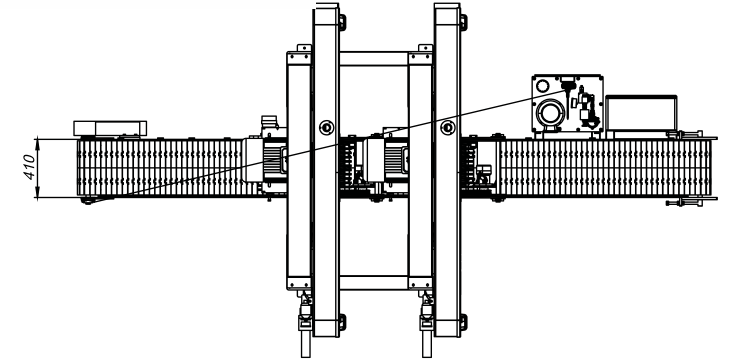
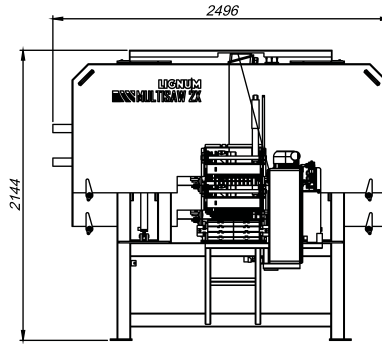
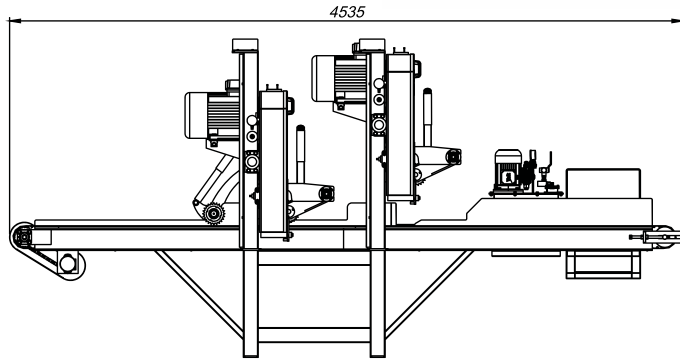
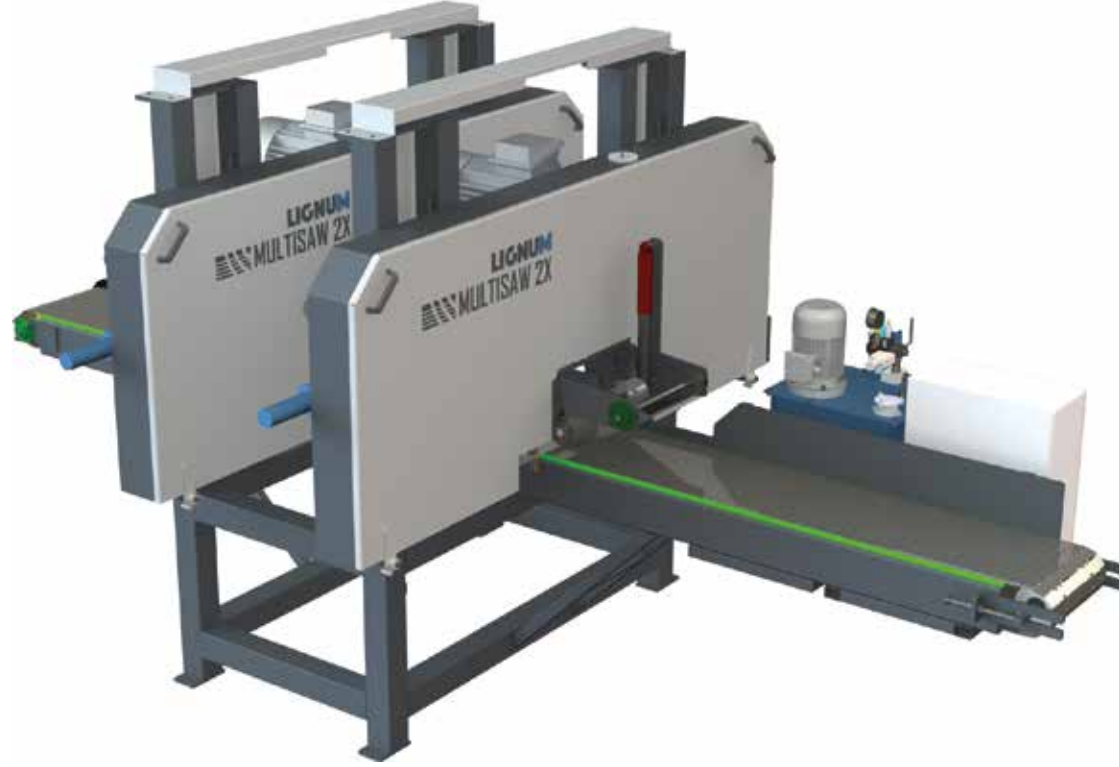

Malzeme Geçiş Yüksekliği	Min. 20 mm – Maks. 150 mm
Malzeme Geçiş Geniřlięi	Min. 150 mm – Maks. 400 mm
Kesim Yükseklięi	Min. 10 mm – Maks. 200 mm
Kesme Hızı	Min. 5 m/dk – 20 m/dk

Konveyör Geniřlięi	400 mm
Konveyör Uzunluęu	400 mm
Aęırlık	3100 kg
Testere Motor Gücü	15 kW



Kesme Derinliği 145 mm

Testere Motor Gücü 11 kW

Dairesel Testere Çapı Ø 450 mm

Pozisyonlama Sistemi Joystick Kol (*Aşağı-Yukarı, Sağ-Sol Manuel*)

Pozisyonlama Hareketi Hidrolik

Hidrolik Motor Gücü 1,5 kW

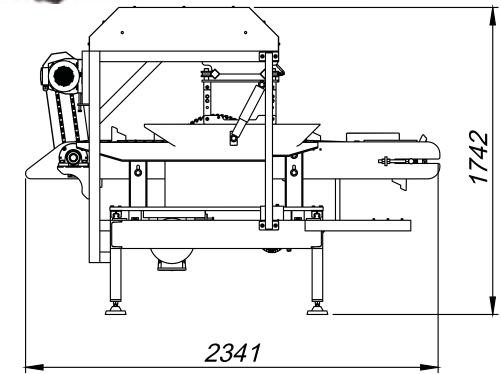
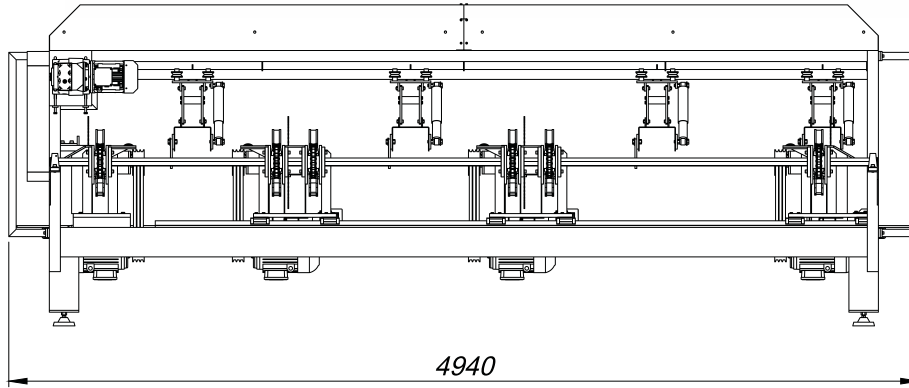
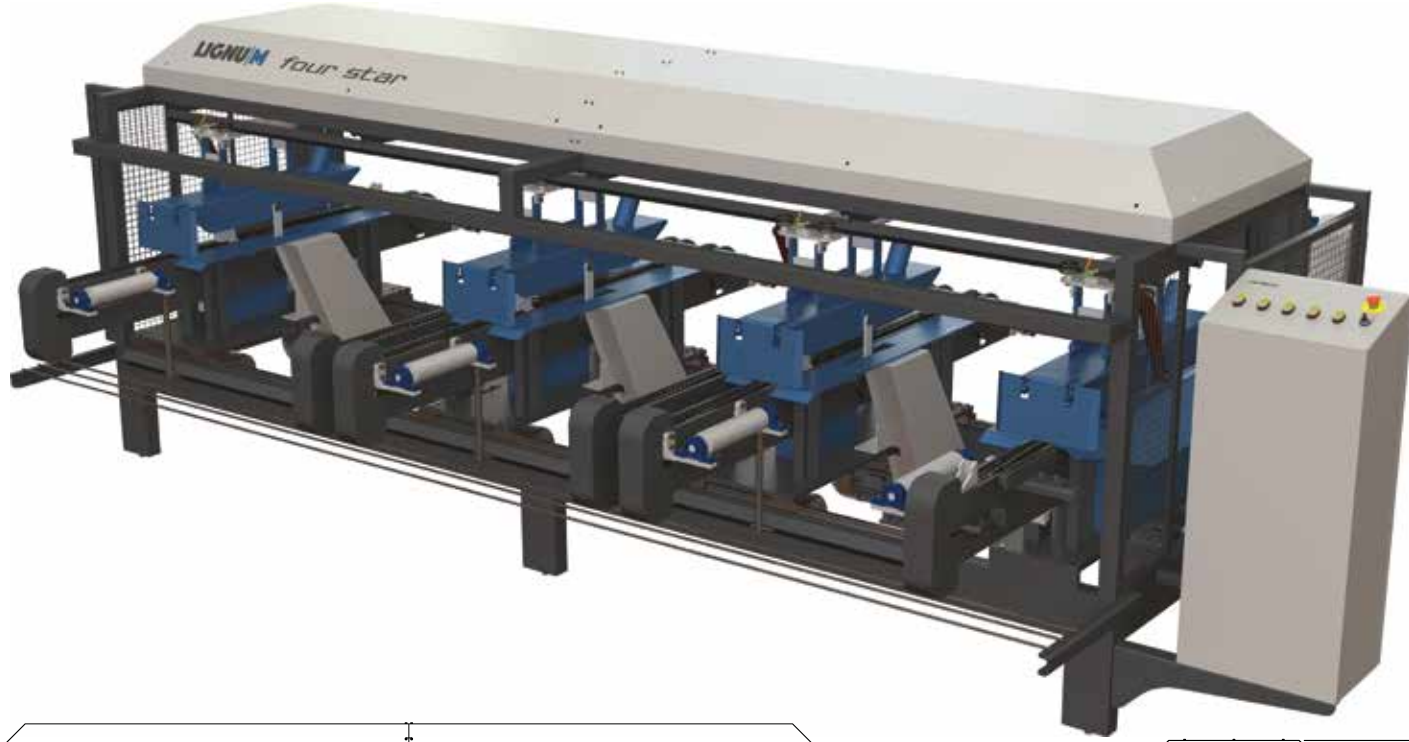

Kesme Uzunluğu	Min. 600 mm – Maks. 4000 mm
Kesme Yüksekliği	Min. 10 mm – Maks. 150mm
Kesme Genişliği	Min. 20 mm – Maks. 600 mm
Testere Motor Gücü	7,5 kW x 4
Besleme Motoru	1,5 kW (Hız Ayarlı)

Ayarlayıcı Motor (Ölçü)	0,75 kW x 3 (Frenli)
Ölçü Ayarlama	Motorlu (Lineer bilyalı rulman)
Ölçü Aleti (Ekran)	Mekanik – Dijital (Opsiyonel)
Besleme	Manuel
Testere Çapı	Ø 500 mm

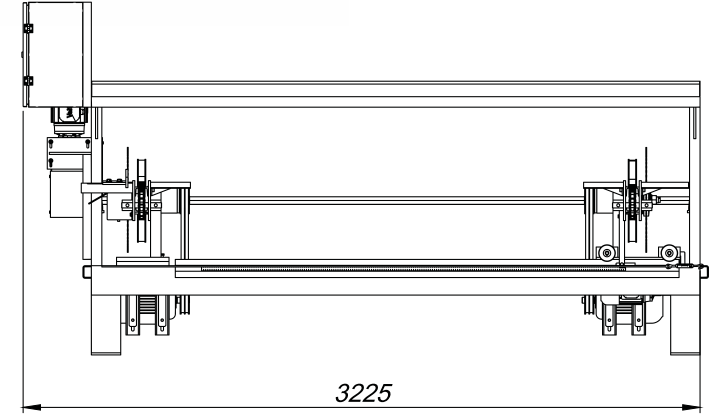
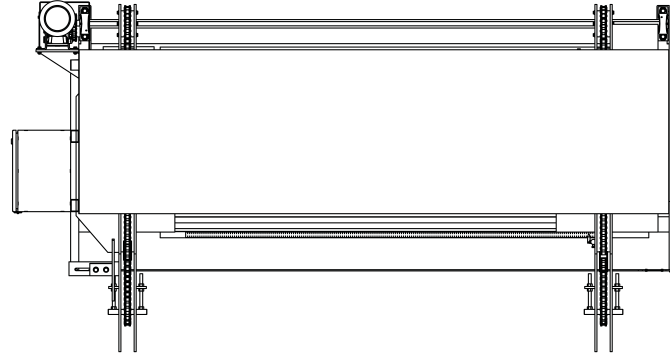
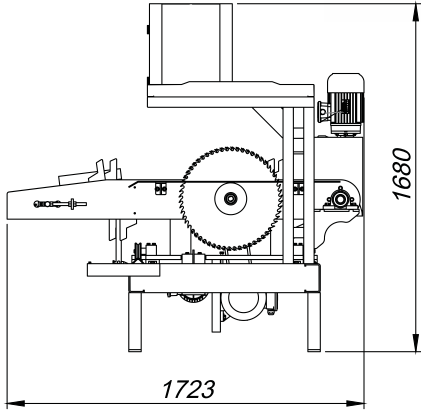

Kesme Uzunluğu	Min. 600 mm – Maks. 2400 mm (Maks. uzunluk opsiyoneldir)
Kesme Yüksekliği	Min. 10 mm – Maks. 150mm
Kesme Geniřlięi	Maks. 600 mm
Testere Motor Gücü	5,5 kW x 2
Besleme Motoru	1,5 kW (Hız Ayarlı)

Ayarlayıcı Motor (Ölçü)	0,75 kW (Frenli)
Ölçü Ayarlama	Motorlu
Ölçü Aleti (Ekran)	Mekanik – Dijital (İsteęe baęlı)
Besleme	Manuel
Testere Çapı	Ø 500 mm

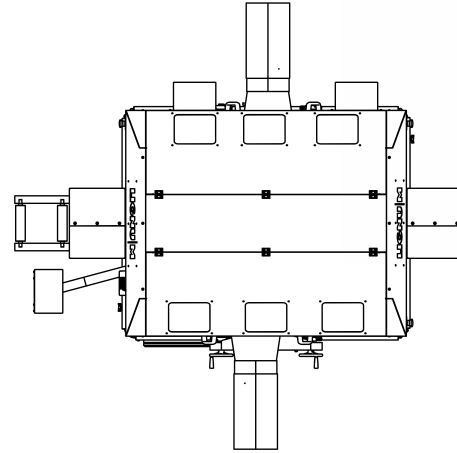
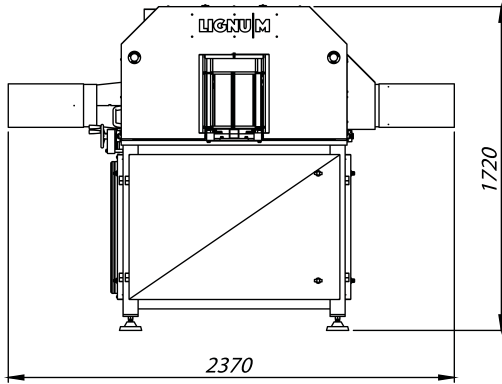
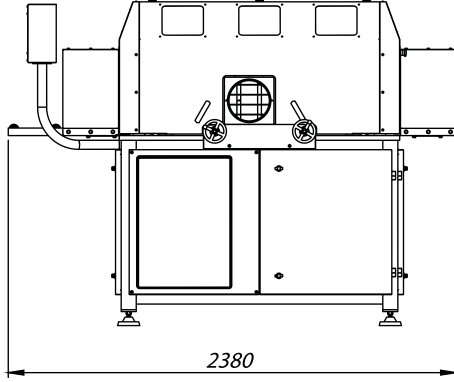

Testere Motor Gücü	22 kW x 2
Redüktör Motor Gücü	1,5 kW x 2
Kesme Genişliği	Min. 60 mm – Maks. 180 mm
Kesme Yüksekliği	330 mm

Pnömatik Baskı Sistemi	6 Bar
Genişlik	160 cm
Uzunluk	215 cm
Yükseklik	172 cm
Ağırlık	1670 kg

Kesme Hızı	8 metre/dakika
Testere Mil Çapı	Ø 70 mm
Testere Çapı	Ø 300 mm

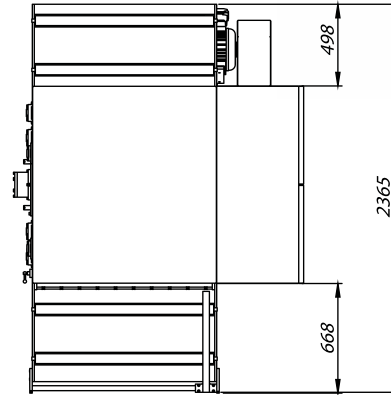
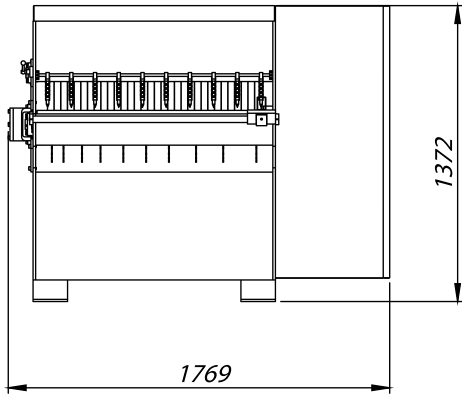
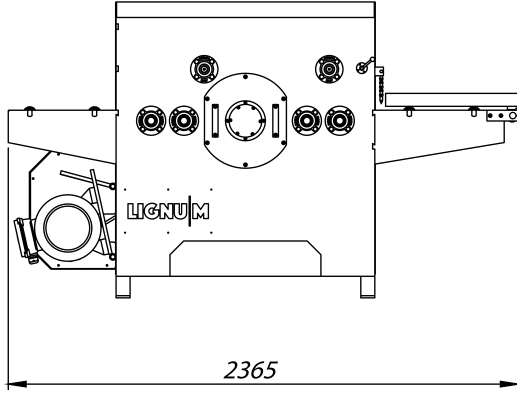

Kesme Yüksekliği	Min. 15 mm – Maks. 100 mm
Mil Kullanım Alanı	980 mm
Dairesel Testere Mil Motoru	15 kW
Dairesel Testere Çekirdek Çapı	Standart Ø 75 mm

Dairesel Testere Çapı	Ø 350 mm
Besleme	Manuel + Otomatik
Toplam Güç	16,5 kW
Ağırlık	1500 kg

NOT: Testere menzili müşteri gereksinimlerine göre değişebilir.

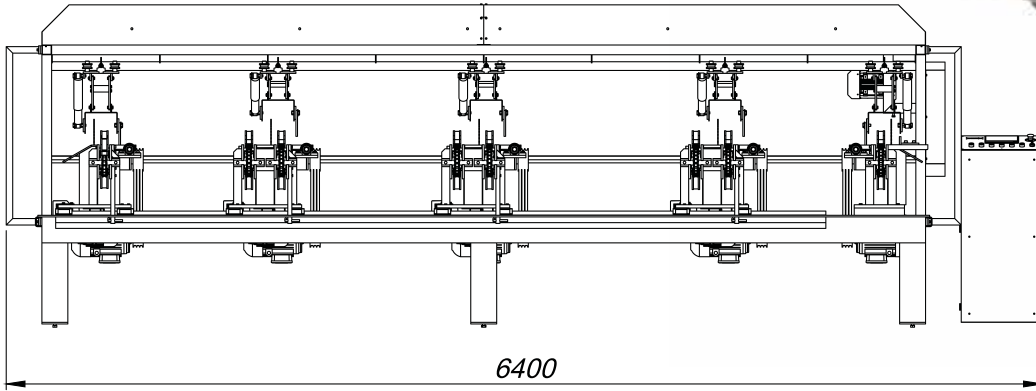
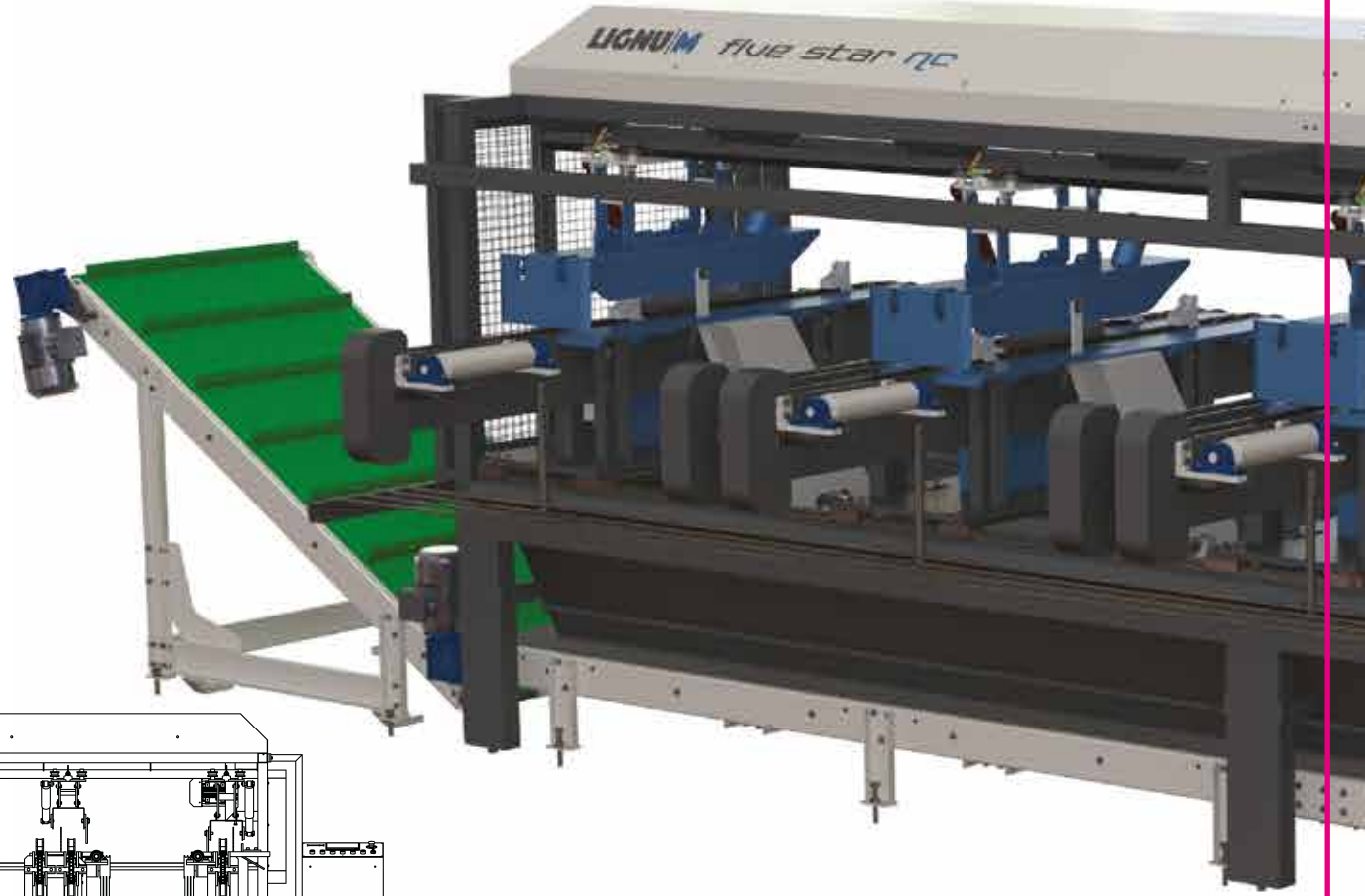

Kesme Yüksekliği 150 mm
Kesme Uzunluğu Min. 650 mm – Maks. 1200 mm x 4
Kesme Genişliği 600 mm

Testere Motor Gücü 7,5 kW x 5
Testere Çapı Ø 500 mm

BEŞLİ BOYLAMA MAKİNESİ – LIGNUM FIVE STAR

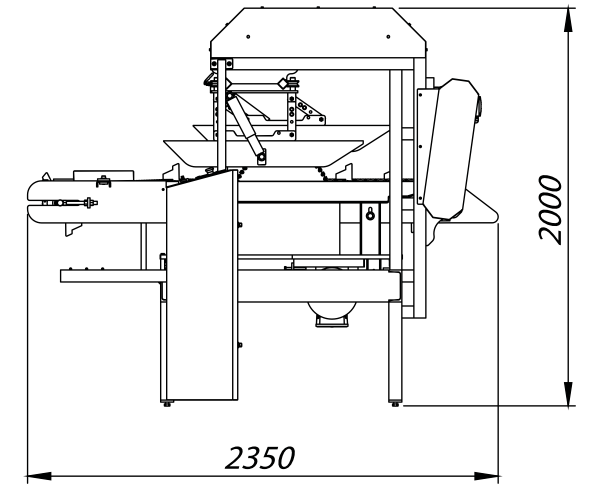

Dijital Otomatik Hız Ayarlaması

Besleme Motoru 1,5 kW (*Hız Ayarı*)



- * Ekstra kalın ana gövde
- * Sert döküm alaşım çarklar
- * Hidrolik testere germe sistemi
- * Elektrikli sağ-sol hareket edebilen testere
- * Manuel olarak yukarı-aşağı ve ileri-geri ayarlanabilir

- * Hidrolik Tomruk Çevirme Sistemi
- * Tomruk/Üst kapak bant ve konveyörleri opsiyoneldir
- Üst pres ruloları Pnömatik Baskı Sistemi
- Ölçü Ayarlama Redüktör Motorlu (Dijital)

ÜÇ KAPAK PRİZMA MAKİNESİ

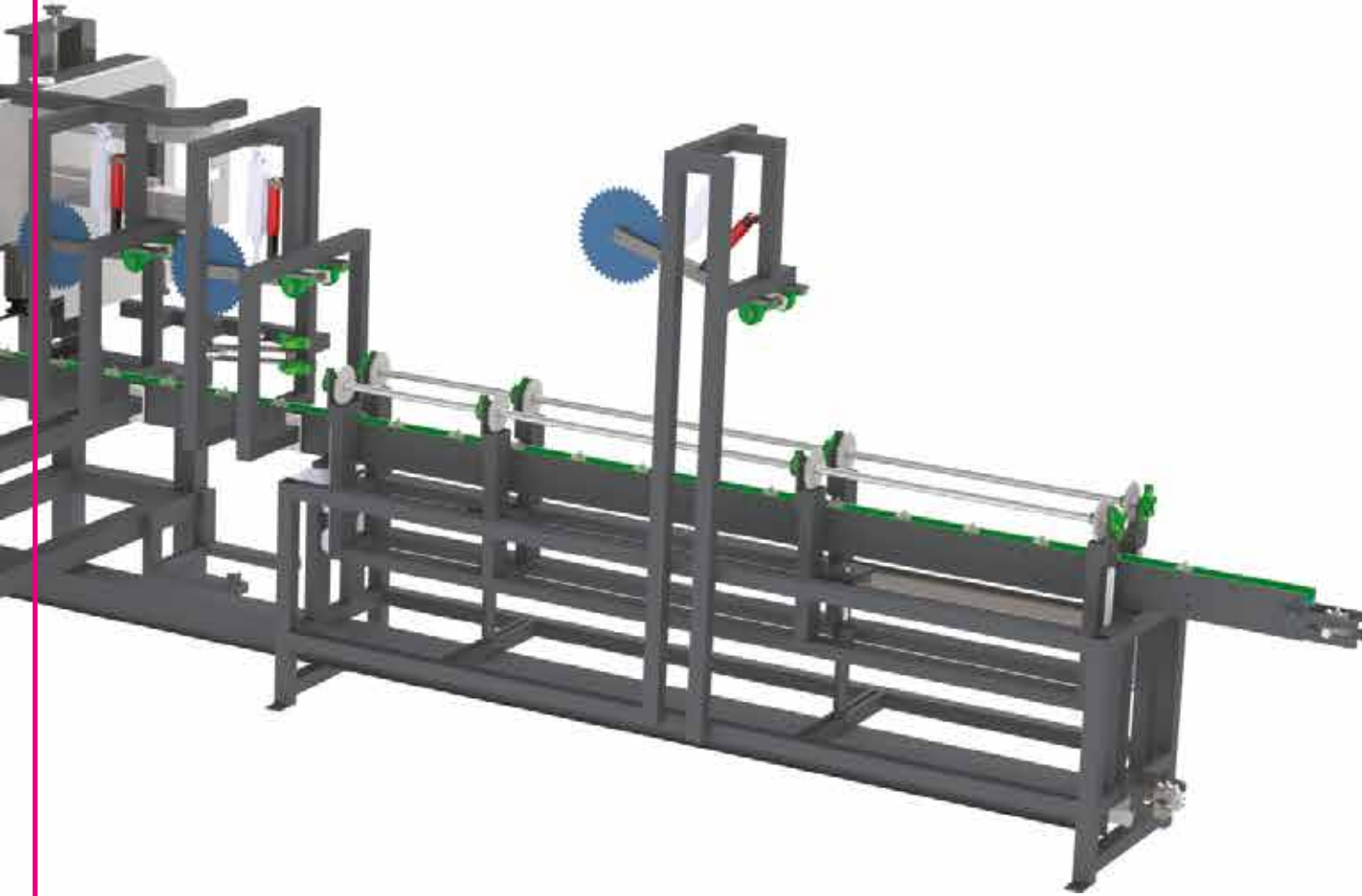

Minimum Kesme Derinliđi 90 mm
Maksimum Kesme Derinliđi 250 mm
Ana Motor 11 kW x 3

Kasnak apları Ø 830 mm
Kasnak Geniřliđi 40 mm
İlerleme Hızı 0 - 30 metre / dakika

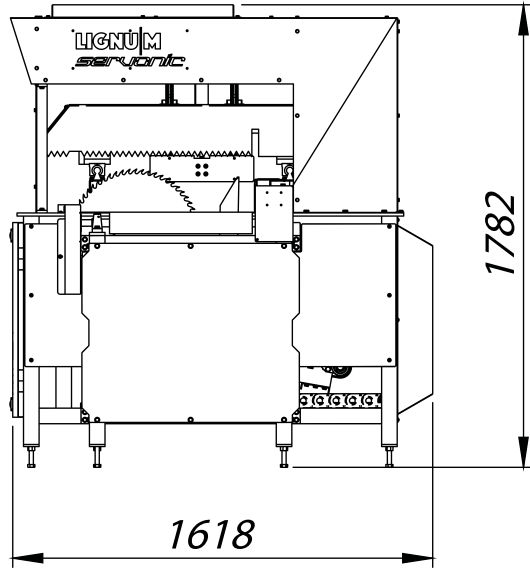

Kesme Yüksekliği Min. 10 mm – Maks. 170 mm
Kesme Uzunluğu Min. 50 mm – Maks. 3000 mm **(4000 mm'ye kadar opsiyonel)**

Kesme Genişliği 500 mm
Ağırlık 1120 kg

OTOMATİK SERVOLU BOYLAMA MAKİNESİ – LIGNUM SERVONIC

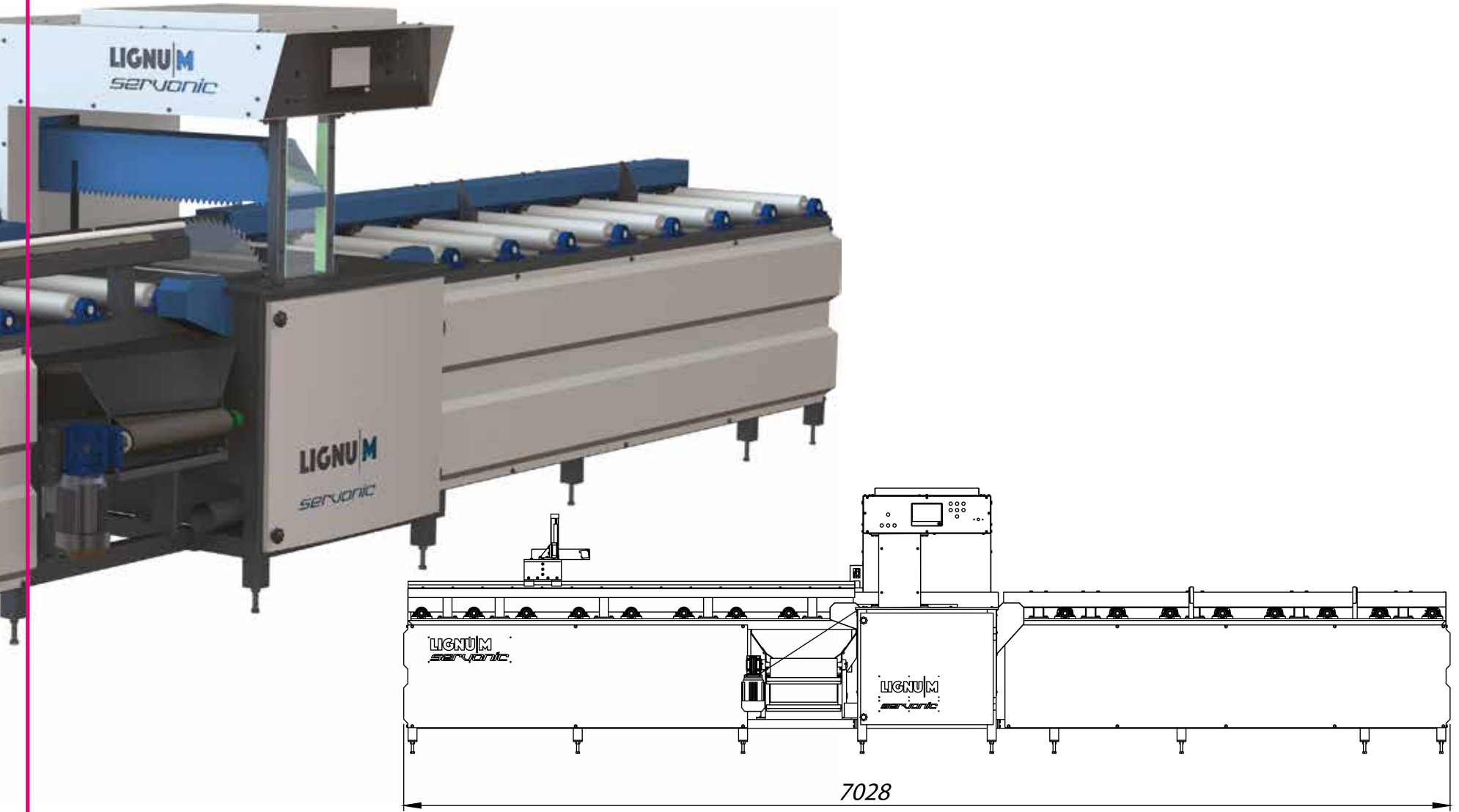

Testere Motor Gücü 11 kW
Testere Çapı Ø 500 mm

Besleme Manuel + Otomatik
Toplam Güç Min. 15 kW

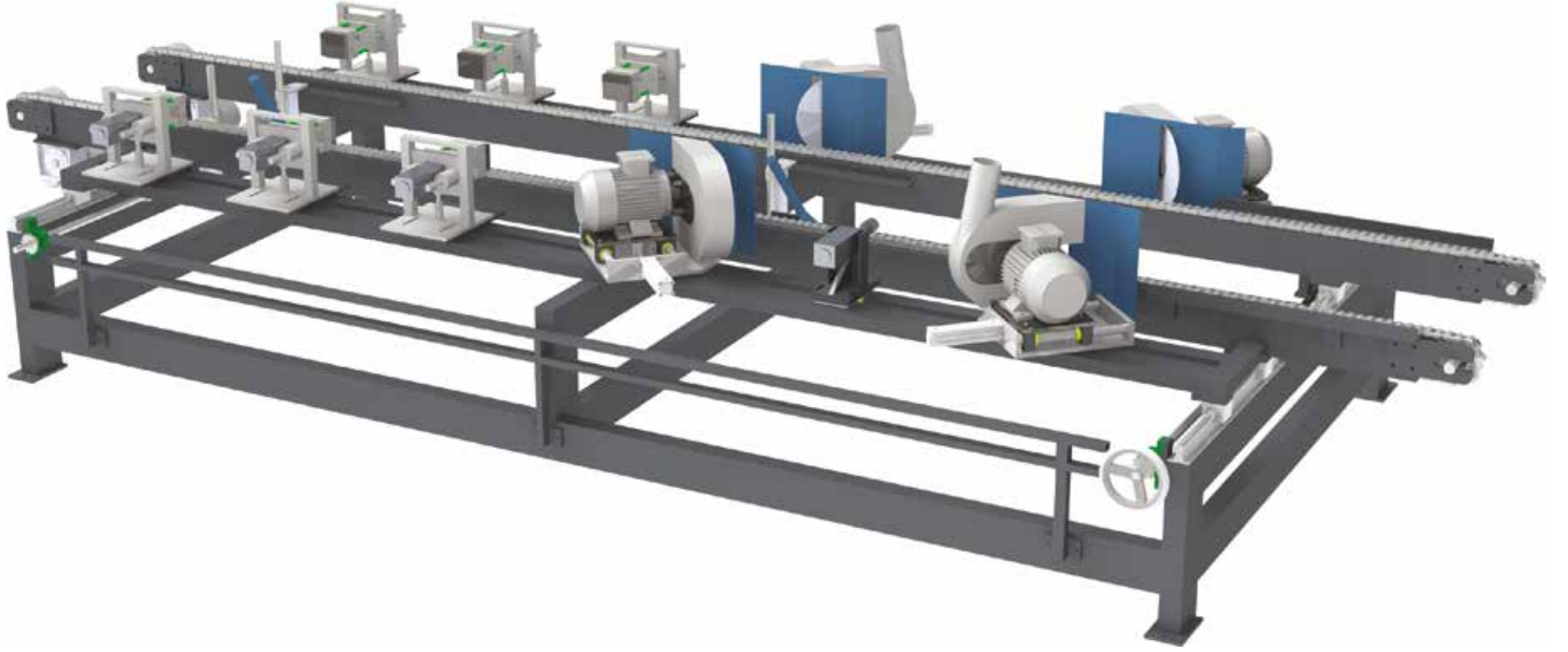

Köşe Kesme

Testere Çapı	Ø 250 mm
Testere Hareketi	2,2 kW
Testere Motor Gücü	2,5 kW x 4

Palet Damgalama

Damgalayıcı Isıtma Sistemi	Elektrik rezistansı
Damgalayıcı Yazdırma Sistemi	Pnömatik
Mühür Damgalayıcı	Çelik rezistanslı

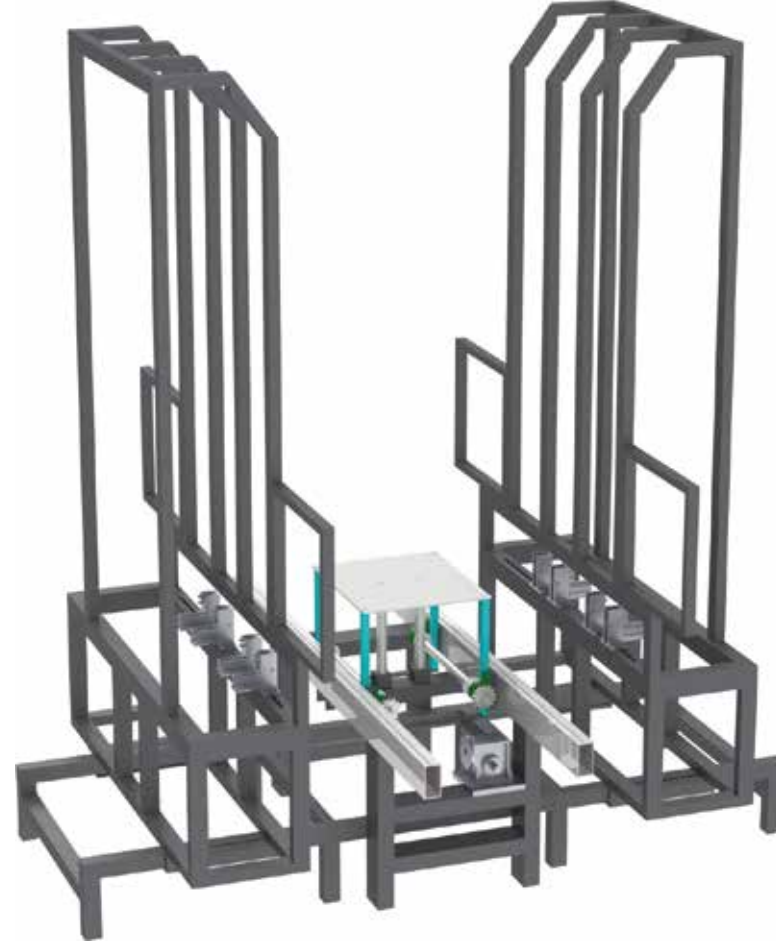

İstifleme Sistemi Hidrolik

Konveyör Motor Gücü 1,5 kW

Maksimum İstifleme Üst üste 20 parça



Testere Motor Gücü 11 kW
Çalışma Basıncı 6 Bar

* Pedalla manuel kontrollü bas-durdur ayarı

Kesme Yüksekliği 170 mm
Kesme Geniřliđi 500 mm
Kesme Uzunluđu Ayarlanabilir

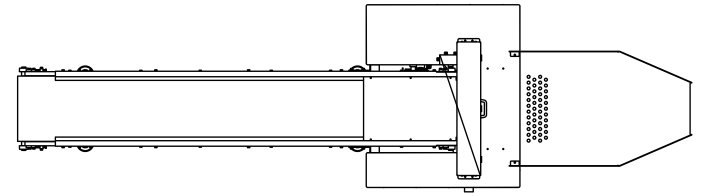
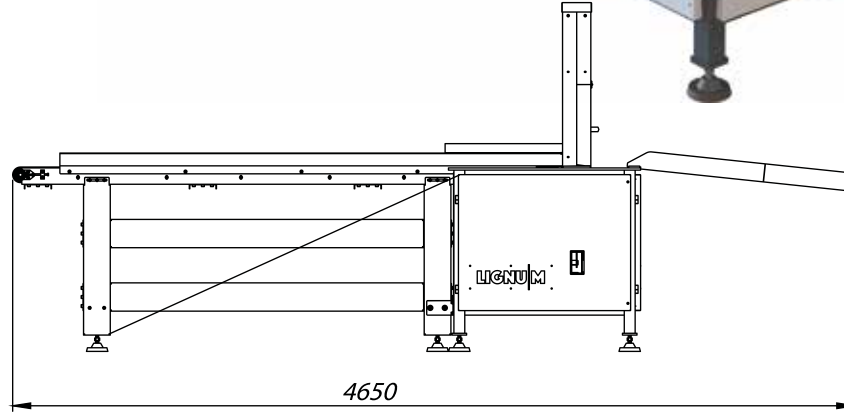
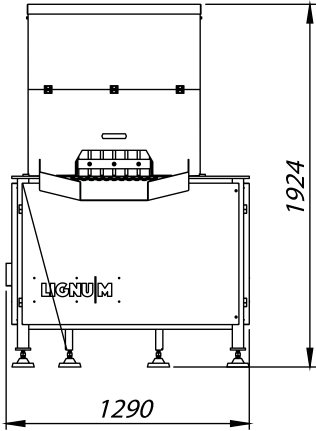

Testere Motor Gücü	7,5 kW
Redüktör Motor Gücü	0,75 kW x 2
Çalışma Hava Basıncı	6 Bar
Kesme Yüksekliği	130 mm
Kontrol Tipi	Panel PLC

Kesme Geniřliđi	400 mm
Kesme Uzunluđu	Otomatik Ayarlanabilir
Kesme Hızı	Saatte 1/1,5 ton
Çalışma Sistemi	Pnömatik

Ağırlık	700 kg
Geniřlik	1400 mm
Uzunluk	4600 mm
Yükseklik	1650 mm

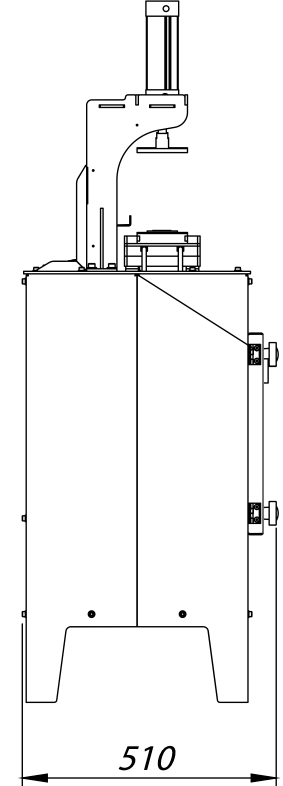
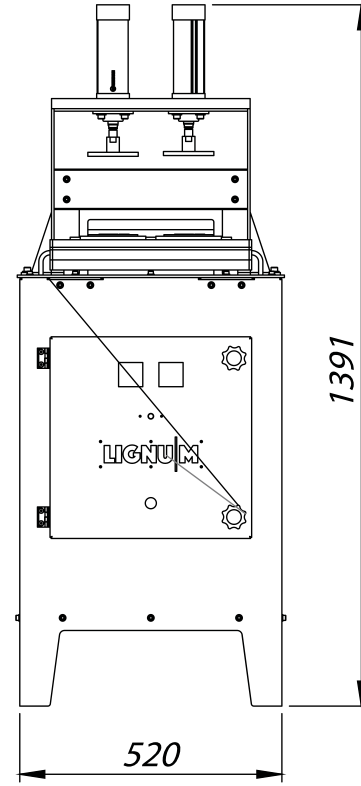

Pnömatik Sistemi

Damgalama Isısı 500 °C

Baskı Zaman Ayarlı

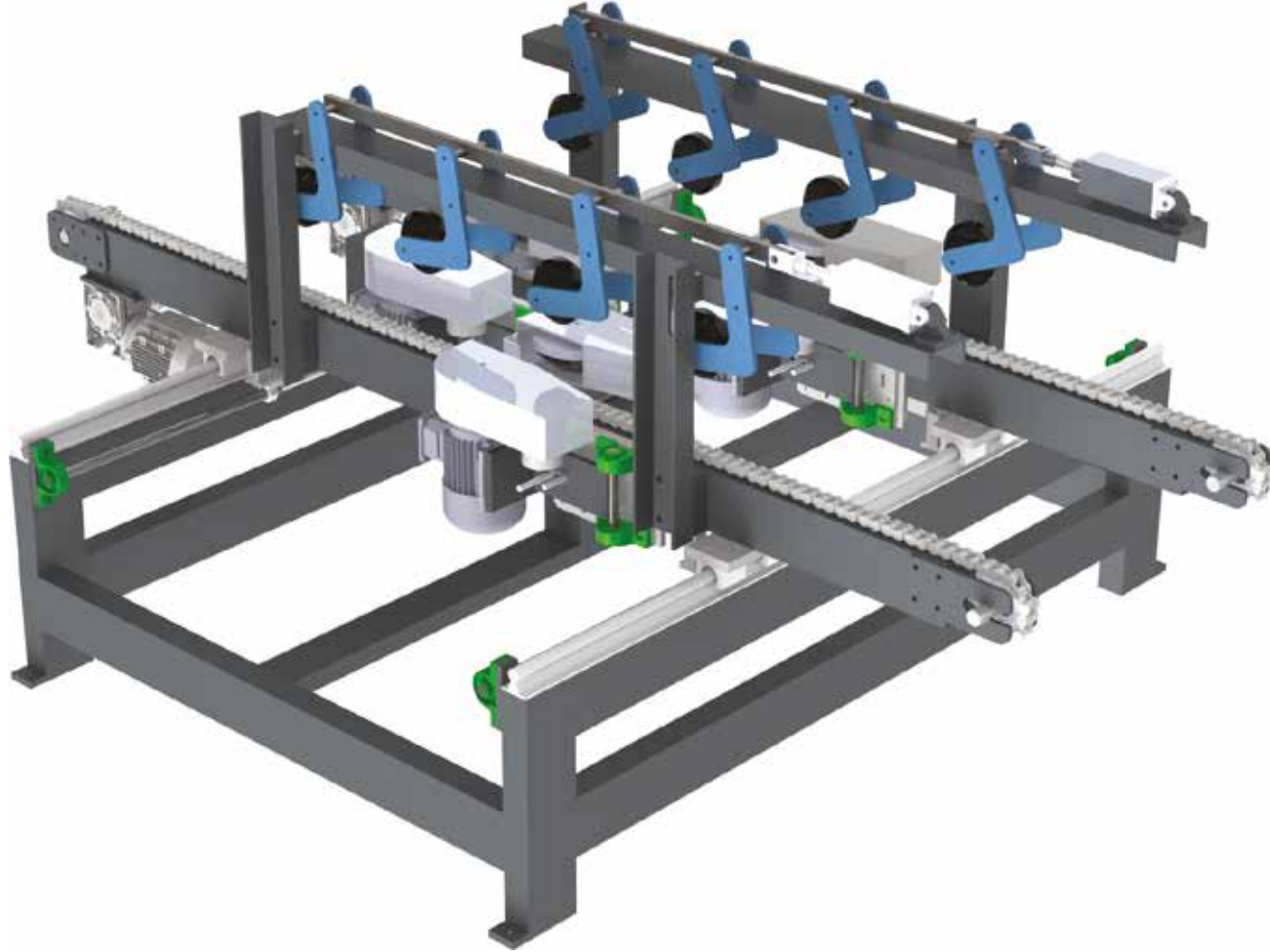

6 Parça Özel Pah Kırma Bıçağı
Pnömatik Baskı

Motor Gücü 6 adet 1,1 kW motor
Çalışma Basıncı 6 Bar



- * 26 parça çivi tabancası
- * 3 farklı boyda çivileme ölçüsü
- * Standart Euro Palet Tip
- * Ayarlanabilir çivileme mesafesi ve çivi derinliği
- * Otomatik yağlama sistemi kılavuzu

Palet Uzunluğu	Min. 1100 mm – Maks. 1400 mm	Araba Hareketi	Redüktör Motorlu
Palet Çivileme Genişliği	Maks. 1850 mm	Toplam Güç	22 kW
Kapasite	1 palet/ dakika	Genişlik	240 mm
Çivi Tipi	Dökme çivi	Uzunluk	320 mm
Çivi Besleme Ünitesi	Pnömatik	Yükseklik	300 mm
Kontrol Tipi	PLC Kontrol	Ağırlık	3350 kg



Testere Motor Gücü 7,5 kW
Konveyör Motor Gücü 0,75 kW
Çalışma Hava Basıncı 6 Bar
Kasnak Çapı Ø 600 mm

Kasnak Geniřliđi 50 mm
Çalışma Sistemi Pnömatik
Kesme Geniřliđi 1600 mm

Geniřlik 1200 mm
Uzunluk 4500 mm
Yükseklik 1700 mm
Ađırlık 1100 kg



Boyuna Konveyör Zincir Tipi

Enine Konveyör Zincir Tipi

Makara Çapı

Min. 700 mm – Maks. 1600 mm

Makara Delik Çapı

Min. 50 mm – Maks. 150 mm

Makara Kalınlığı

Min. 20 mm – Maks. 100 mm

Makara Döndürme Ünitesi

Servo Redüktörlü Otomatik

MAKARA İŞLEME HATTI



Makara Çevirme Redüktörü 3 kW

Saplama Motoru 4 kW

Pinol Deliği Motoru 4 kW

Kanal Açma Motoru 5,5 kW

Muz Kanalı Motoru 11 kW

60'lık Şerit Motoru 11 kW

Pah Kıрма Motoru 3 kW

Ünite Hareketleri Hidrolik Hız Ayarlı

Üniteler Sağ-Sol Hareketli
Konveyör Motoru 0.75 kW (**Redüktörlü**)



İşleme Boyutları Min. 800 mm – Maks. 3000 mm

Hidrolik Motor Gücü 15 kW

Çivi Besleme Ünitesi 2 adet

Çivileme Tabancası Maks. 24 adet

Yükseklik 2500 mm

Uzunluk 4500 mm

Genişlik 1200 mm

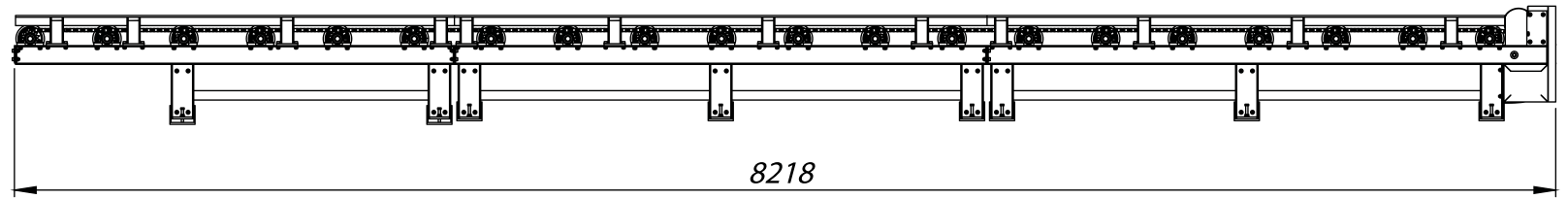
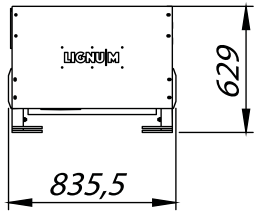
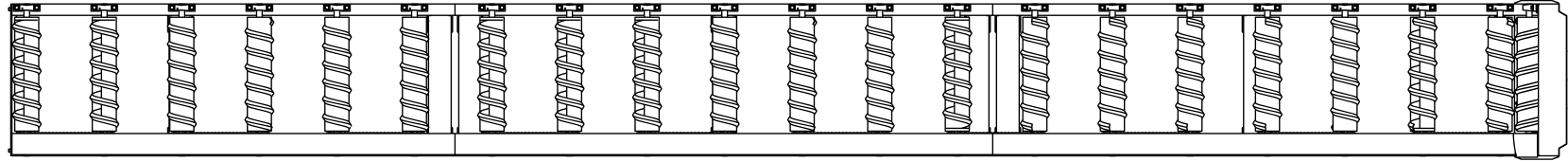

Motor Gücü 1,5 kW

Redüktör Gücü Opsiyonel

Genişlik ve Uzunluk Opsiyonel

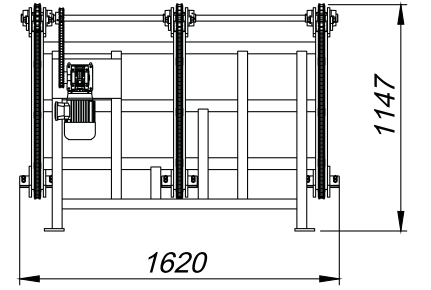
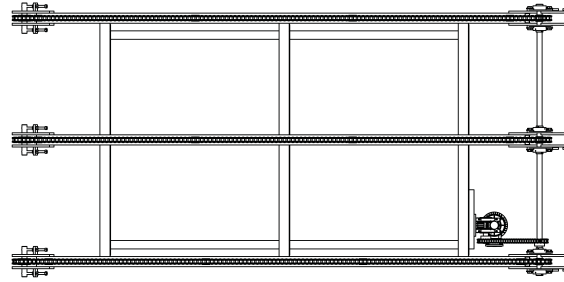
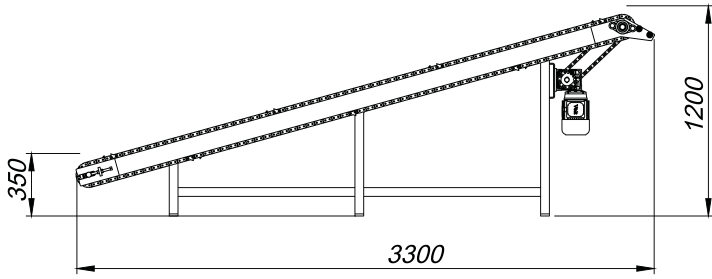
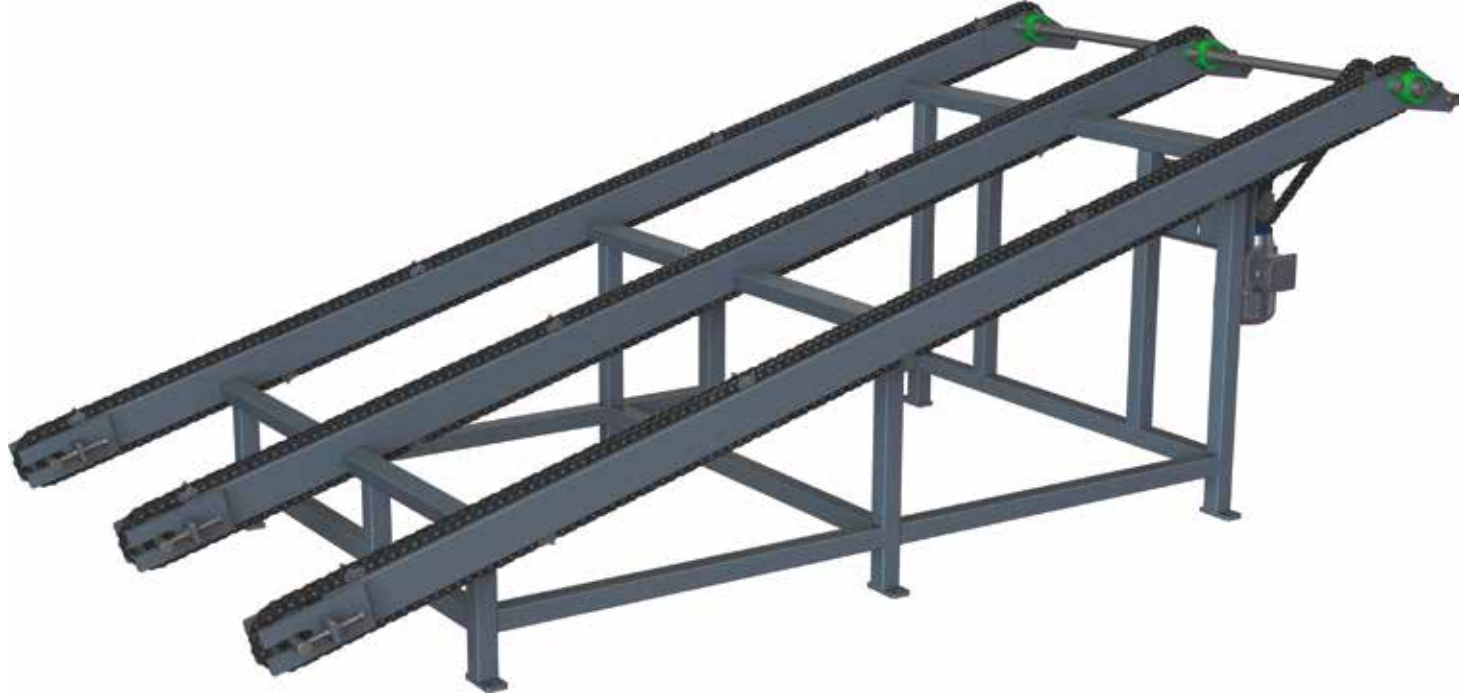

Motor Gücü Opsiyonel

Redüktör Gücü Opsiyonel

Genişlik ve Uzunluk Opsiyonel



Zincir Sayısı 3 veya 4 (**Opsiyonel**)

Yükseklik Opsiyonel

Genişlik ve Uzunluk Opsiyonel

Tomruk Devirme Pnömatik

Motor Gücü 4 kW Redüktörlü



LIGNUM

AĞAÇ İŞLEME MAKİNELERİ

NEWajans

 Dumlupınar Mh., Esentepe Cd.,
No: 7/1, Posta Kodu: 16240,
Nilufer, Bursa, TÜRKİYE

 +90 [224] 480 00 98

 sales@lignum.com.tr
 www.lignum.com.tr